

- (1976).
 (30) G. Larsson and I. Nahringsbauer, *Acta Crystallogr., Sect. B*, **24**, 666 (1968).
 (31) J. C. Speakman and H. H. Mills, *J. Chem. Soc.*, 1164 (1961).
 (32) G. E. Bacon and N. A. Curry, *Acta Crystallogr.*, **13**, 717 (1960).
 (33) L. Manojlovic and J. C. Speakman, *Acta Crystallogr., Sect. B*, **64**, 323 (1968).
 (34) M. F. Ansell and R. H. Gigg, "Rodd's Chemistry of Carbon Compounds", Vol. 1c, 2nd ed, S. Coffey, Ed., Elsevier, Amsterdam, 1965, pp 139-142.
 (35) Cis and trans refer to the orientation of the carboxylate groups with respect to the O...H...O hydrogen-bond axis.

Prototypes for Aliphatic and Aromatic Diazonium Ions. An ab Initio Study of the Methane- and Benzenediazonium Ions

Mark A. Vincent and Leo Radom*

Contribution from the Research School of Chemistry, Australian National University, Canberra, A.C.T. 2600, Australia. Received October 25, 1977

Abstract: Ab initio molecular orbital calculations with minimal (STO-3G) and split-valence (4-31G) basis sets have been carried out for open and bridged structures of the methanediazonium (MDI) and benzenediazonium (BDI) ions. Theoretical geometries and relative energies are reported. Open structures are preferred for both MDI and BDI with N≡N lengths in both cases similar to that in molecular nitrogen. Although the C-N bond is considerably shorter in BDI than in MDI, binding energies calculated with respect to the appropriate parent cation + nitrogen are in the reverse order. The N_αN_β rearrangement in open MDI is predicted to proceed via a symmetric bridged transition state. In contrast, the N_αN_β rearrangement in BDI is predicted to proceed via an asymmetric transition state in which one of the nitrogens is weakly bound to a ring carbon and the other not at all. A symmetric bridged structure is predicted to be a metastable intermediate in this rearrangement, lying in a high-energy shallow potential well. The N₂⁺ substituent is found to be a powerful σ-electron acceptor and π-electron acceptor.

Introduction

It is more than a century since diazonium ions were first discovered,¹ and in the intervening period their reactions have been studied in great detail.²⁻⁴ In contrast, our knowledge of some of their fundamental physical properties, notably their structures and energies, is fragmentary. Thus no experimental structural data have been reported for any simple aliphatic diazonium salt, and the only simple diazonium cation, aliphatic or aromatic, for which an experimental heat of formation appears to be available is the methanediazonium ion.⁵ As a result, there are many questions about diazonium ions that remain to be answered. Of particular interest is the relationship between structure and stability in the various diazonium ions. In addition, there are certain aspects of diazonium ion chemistry which have been extensively studied experimentally, for which it would be desirable to have more direct information. The precise nature of the transition state for the N_αN_β rearrangement in the benzenediazonium ion is one such example.

A promising source of such information is ab initio molecular orbital theory. This has been used extensively in previous structural and energetic studies of organic systems⁶ and, in particular, for studying organic cations.⁷ In this paper, we use such a theoretical procedure to study the structures and stabilities of the methane- and benzenediazonium ions.

Previous theoretical work on diazonium ions has generally been limited to semiempirical treatments, usually on the benzenediazonium ion.^{8,9} Of these, we note particularly the interesting paper by Van Dine and Hoffmann⁹ on rearrangements in diazonium ions (and related systems). Recently, a detailed study of the protonation of diazomethane has been reported.¹⁰ This work included CNDO/2 and MINDO/3 optimizations of the methanediazonium ion together with single calculations at the STO-3G and 4-31G levels. The main point of the study, however, was to compare C- vs. N-proton-

ation in diazomethane. Finally, STO-3G calculations on substituted benzenediazonium ions have recently been reported¹¹ in which the effect of substituents on the stabilities of phenyl cations and benzenediazonium ions is compared.

Method and Results

Standard ab initio LCAO SCF molecular orbital calculations were carried out using a modified version of the Gaussian 70 system of programs.¹²

Open (**1**) and bridged (**2a**, **2b**) structures of the methanediazonium ion were fully optimized, except for specified symmetry constraints, using a gradient optimization procedure¹³ and the minimal STO-3G¹⁴ and split-valence 4-31G¹⁵ basis sets. Optimized geometries are shown in Figure 1 together with previously reported^{16,17} data for CH₃⁺ (**3**, STO-3G and 4-31G) and N₂ (**4**, STO-3G) included for reference. Corresponding energies are listed in Table I. In order to determine the activation energy for a possible N_α-N_β rearrangement in **1**, direct transition state calculations¹⁸ were carried out yielding the structure (**2c**) shown in Figure 4. In this procedure,¹⁸ the transition state is characterized as having near-zero values (within a specified tolerance) of the first derivatives of energy, and one negative eigenvalue for the second derivative energy matrix. Charge distributions with the STO-3G basis derived using the Mulliken approach¹⁹ are given in Figure 5.

For the open (**5**) and bridged (**6**) structures of the benzenediazonium ion, full STO-3G optimization was carried out, subject only to specified symmetry constraints and the assumption of 1.083 Å (the optimized value in benzene²⁰) for the length of the C-H bonds. An optimization of the phenyl cation (**7**) with the same assumption concerning C-H lengths was also carried out. Our structure (**7**) has an energy 3 kcal mol⁻¹ lower than that of a recently reported²¹ STO-3G structure, reflecting a more complete geometry optimization. Optimized structures for the aryl systems are displayed in Figure 7 and corre-

Table I. Calculated Total Energies (hartrees) for the Methanediazonium Ion and Related Systems

		STO-3G/STO-3G	4-31G/STO-3G	4-31G/4-31G
CH ₃ N ₂ ⁺ (open)	1	-146.362 38	-147.962 57	-147.974 76
CH ₃ N ₂ ⁺ (bridged)	2a	-146.287 87	-147.898 75	-147.929 93
CH ₃ N ₂ ⁺ (bridged)	2b	-146.287 87	-147.898 86	-147.929 93
CH ₃ N ₂ ⁺ (transition state)	2c	-146.287 85	-147.898 65	
CH ₃ ⁺	3	-38.779 48	-39.171 29	-39.175 12
N ₂	4	-107.500 65	-108.746 88	-108.754 22

Table II. Calculated Binding Energies (kcal mol⁻¹) for Methane- and Benzenediazonium Ions

		STO-3G/STO-3G
CH ₃ N ₂ ⁺ (open)	1	51.6 (27.9, ^a 28.5, ^b 38 ^c)
CH ₃ N ₂ ⁺ (bridged)	2	4.9 (-12.1, ^a 0.4 ^b)
C ₆ H ₅ N ₂ ⁺ (open)	5	44.3
C ₆ H ₅ N ₂ ⁺ (symmetric bridged)	6	10.0

^a 4-31G/STO-3G value. ^b 4-31G/4-31G value. ^c Experimental value calculated using data in ref 5 and 25.

Table III. Calculated Total Energies (hartrees) for the Benzenediazonium Ion and Related Systems

		STO-3G/STO-3G
C ₆ H ₅ N ₂ ⁺ (open)	5	-334.560 07
C ₆ H ₅ N ₂ ⁺ (symmetric bridged)	6	-334.505 43
C ₆ H ₅ ⁺ ^a	7	-226.988 78

^a 4-31G/STO-3G energy: -229.425 40.

sponding energies in Table III. Again, in order to determine the transition state for intramolecular N_αN_β rearrangement in the benzenediazonium ion, direct transition state calculations were carried out. The model used in these calculations is described in detail below and the resultant structure is shown in Figure 11. Charge distributions for the benzenediazonium ion and related systems are displayed in Figure 9.

Calculated binding energies of the diazonium ions RN₂⁺ with respect to R⁺ + N₂ are shown in Table II. We note that our calculations refer to separated vibrationless species in the gas phase at 0 K temperature.

Discussion

Methanediazonium Ion. We begin by examining the structures of the open and bridged forms of the methanediazonium ion (Figure 1) for which there are no experimental data available. In the open structure **1**, the striking feature is the N≡N length. Both STO-3G and 4-31G results show that the N≡N bond length in **1** is only slightly different from corresponding values (i.e., with the same basis set) in N₂ (**4**). This result, which may seem surprising at first glance, is easily rationalized in terms of the orbital interaction diagram shown in Figure 2. The primary interaction occurs between an essentially lone pair orbital²² (ψ₇^N) on N₂ and the lowest unoccupied orbital (ψ₅^M) of CH₃⁺, which is the 2p orbital at C⁺. Since ψ₇^N is not heavily involved in bonding *within* the N₂ fragment, this interaction does not result in a significant change in the N≡N length on formation of the diazonium ion. The C-N length in **1** (1.513 Å with 4-31G) is slightly longer than normal C-N single bonds (e.g., the experimental value²⁴ in CH₃NH₂ is 1.474 Å).

The bridged structures **2a** and **2b** are connected by a simple methyl rotation which, typically of sixfold barriers, occurs almost freely. The calculated geometric parameters and energies in **2a** and **2b** are almost identical so they can be conveniently discussed together. We refer to **2a** and **2b** as *symmetric bridged structures* because the methyl carbon is equi-

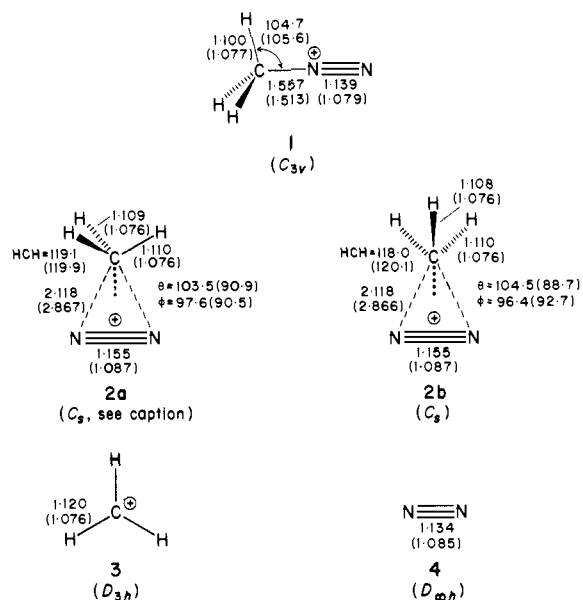

Figure 1. Optimum STO-3G (4-31G) structures for the methanediazonium ion and related systems. θ and ϕ are the angles made by the vertical (\cdots) with the HCH plane and the unique C-H bond, respectively. The bridging carbon in **2a** is constrained to lie on the perpendicular bisector of the N-N bond. Throughout this paper, bond lengths are in ångströms, bond angles in degrees.

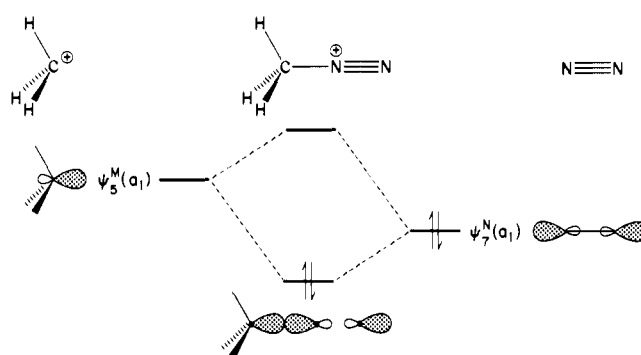

Figure 2. Orbital interaction diagram for the open structure **1** of the methanediazonium ion. Orbitals classified under C_{3v} symmetry.

distant from the two nitrogens. For **2b**, this is required by the C_s symmetry, while for **2a**, we impose this as an additional constraint. The important orbital interaction (Figure 3) in the symmetric bridged structures involves the empty ψ₅^M orbital of CH₃⁺ with the appropriate filled π orbital (ψ₆^N) of N₂. However, partly because of lower overlap, the interaction in **2** is smaller than in **1**. In fact, the C-N distances in **2** are 2.118 (STO-3G) and 2.867 Å (4-31G), indicating a very weak complex and one which is significantly weaker with 4-31G than with STO-3G. We shall comment further on this point later. The N≡N bond, which would be expected to lengthen as a result of withdrawal of bonding electron density associated with the orbital interaction in Figure 3, does indeed do so but

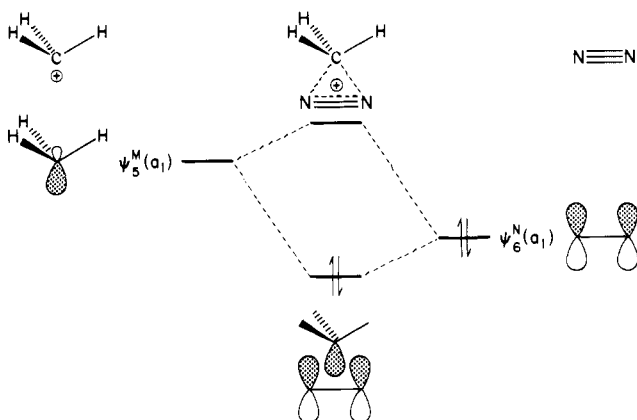

Figure 3. Orbital interaction diagram for the symmetric bridged structure (2a) of the methanediazonium ion. Orbitals classified under effective C_{2v} symmetry.

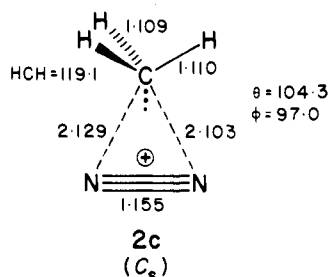

Figure 4. Transition state (2c) for N_{α}, N_{β} rearrangement in the methanediazonium ion (1).

only by 0.021 (STO-3G) or 0.002 Å (4-31G) because of the weakness of the interaction.

Binding energies for the methanediazonium ion, calculated as the difference in energy between **1** and separated CH_3^+ and N_2 , are 51.6 (STO-3G/STO-3G), 27.9 (4-31G/STO-3G), and 28.5 kcal mol⁻¹ (4-31G/4-31G). An experimental value, calculated from $\Delta H_f^\circ(\text{CH}_3\text{N}_2^+) = +223$ kcal mol⁻¹ and $\Delta H_f^\circ(\text{CH}_3^+) = +261$ kcal mol⁻¹, is 38 kcal mol⁻¹. The bridged structures (**2**) are much more weakly bound with a binding energy of 4.9 kcal mol⁻¹ at the STO-3G/STO-3G level and a near-zero value (0.4 kcal mol⁻¹) with 4-31G/4-31G.

The best value of the difference in energy between the bridged (**2**) and open (**1**) structures of the methanediazonium ion is 28.1 kcal mol⁻¹ (4-31G/4-31G). The inadequacies of theory at this level of sophistication in describing small cyclic systems are well known.²⁶ The addition of polarization functions to the basis set and inclusion of electron correlation is likely to preferentially favor **2** compared with **1**. It may also significantly modify the actual geometry of **2** where the bridging C-N lengths seem to be particularly sensitive to the basis set. For a closely related isoelectronic system, the rearrangement $\text{CH}_3\text{NC} \rightarrow \text{CH}_3\text{CN}$ via a bridged transition state is predicted²⁷ by a double ζ basis set (comparable to 4-31G) to require 60 kcal mol⁻¹ activation energy compared with an experimental estimate²⁸ of 38 kcal mol⁻¹.

The question remains as to whether the symmetrically bridged structures (**2a** and **2b**) are transition states (i.e., saddle points) or intermediates (i.e., potential minima) within the intramolecular N_{α}, N_{β} rearrangement in the methanediazonium ion.²⁹ For the related $\text{CH}_3\text{NC} \rightarrow \text{CH}_3\text{CN}$ rearrangement there is some disagreement on this point. Semiempirical MINDO/3 calculations³⁰ predict that the reaction pathway involves a bridged intermediate whereas ab initio calculations²⁷ find only a bridged transition state. We therefore carried out direct calculations for the transition state in the methanediazonium

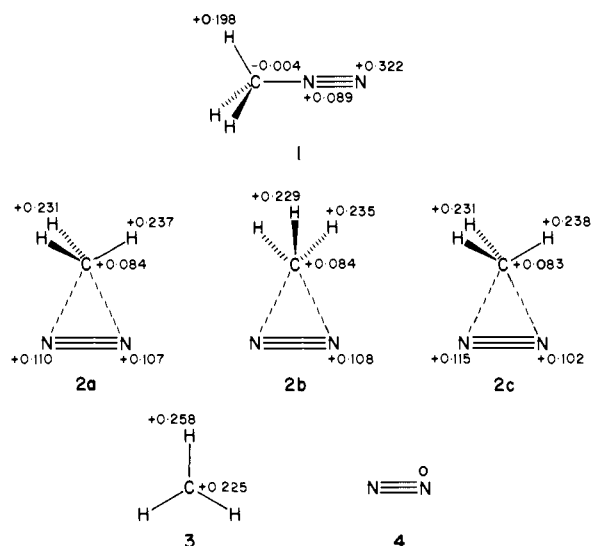

Figure 5. Total STO-3G charges in the methanediazonium ion and related systems.

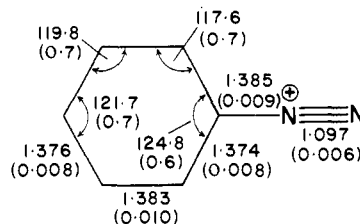

Figure 6. X-ray crystal structure for the benzenediazonium ion (from ref 31). Reported standard deviations in parentheses.

zationium rearrangement. The structure obtained (**2c**, Figure 4) possesses one negative eigenvalue in the energy second derivative matrix as required for a transition state and resembles closely the bridged structure **2a**. We conclude that the N_{α}, N_{β} rearrangement in the methanediazonium ion proceeds via a symmetrically bridged transition state and does not involve a metastable intermediate.

The theoretical charge distributions (Figure 5) show positive charges of +0.41 on N_2 and +0.59 on the CH_3 fragment in the open methanediazonium ion **1**. The bridged structures (**2a**, **2b**, **2c**) all have charges of +0.22 on N_2 and +0.78 on the CH_3 group. Thus, the N_{α}, N_{β} rearrangement is found to be accompanied by increasing positive charge on the migrating methyl group in the transition state, as predicted previously by Van Dine and Hoffmann.⁹

Benzenediazonium Ion. There are a number of experimental structures available for the benzenediazonium ion and related systems^{30,31} with which we can compare our theoretical structure. Of these, the most reliable appears to be that of benzenediazonium chloride reported by Romming³¹ and reproduced in Figure 6. A number of interesting points emerge from a comparison of the theoretical (Figure 7) and experimental (Figure 6) structures. (1) The $\text{N}\equiv\text{N}$ length is only slightly (0.009 Å with STO-3G, 0.003 Å experimentally) longer than the corresponding length in the nitrogen molecule.³² (2) The C-N length is comparable to partially conjugated C-N lengths in molecules such as formamide. Our STO-3G calculations predict that the C-N length in the benzenediazonium ion is shorter by about 0.09 Å than the value in methanediazonium ion. (3) The STO-3G and experimental ring angles are remarkably similar. In particular, they both show a substantial widening at C_1 (angles of 125.2 and 124.8°, respectively), though not to the extent of the widening in the phenyl cation (**7**).

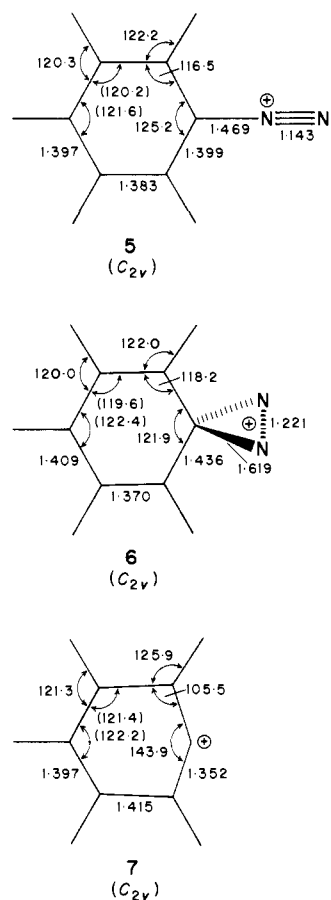

Figure 7. Optimum STO-3G structures for the benzenediazonium ion and related systems. C-H lengths assumed equal to 1.083 Å. Nonindependent parameters in parentheses.

One point on which the theoretical and experimental results disagree is the direction of alternation of the C-C bonds in the ring, about which they produce opposite conclusions. We should note, however, that the experimental results are within experimental error of the theoretical ordering. The theoretical structure can be rationalized quite nicely in terms of an orbital interaction diagram (Figure 8). The main interaction (A) occurs between the filled lone pair orbital (ψ_7^N) on N_2 and a vacant σ -type orbital (ψ_{21}^P) of $C_6H_5^+$ which is largely centered on C_1 . By filling the vacant σ -bonding orbital at C_1 , this interaction could be expected to reverse the structural changes (in particular, the widening of the angle at C_1 and the shortening of C_1-C_2) associated with the removal of a hydride ion from benzene.¹¹ In addition, there are minor interactions B and C which will affect the π -electronic structure and hence the ring bond lengths. B involves the interaction of the filled orbital ψ_{19}^P of $C_6H_5^+$ and the empty π^* orbital (ψ_8^N) of N_2 . This involves removal of bonding electron density from C_1-C_2 , C_3-C_4 , C_4-C_5 , and C_6-C_1 leading to an increase in the length of these bonds, and a removal of antibonding character (and hence a shortening) of C_2-C_3 and C_5-C_6 . This is consistent with our theoretical structure **5**. The same result is obtained from a consideration of the weak interaction C between the filled π orbital (ψ_6^N) on N_2 and the empty orbital ψ_{23}^P on $C_6H_5^+$. In this case, electron density is added to the $C_6H_5^+$ orbital leading to increased bonding in C_2-C_3 and C_5-C_6 and increased antibonding in the remaining bonds. Both of these interactions should also lead to a further decrease in the C-N length and an increase in the $N\equiv N$ length as observed.

The calculated π -electron populations (Figure 9) show that if the benzenediazonium ion is considered as a substituted benzene, the N_2^+ substituent is a more powerful σ -electron

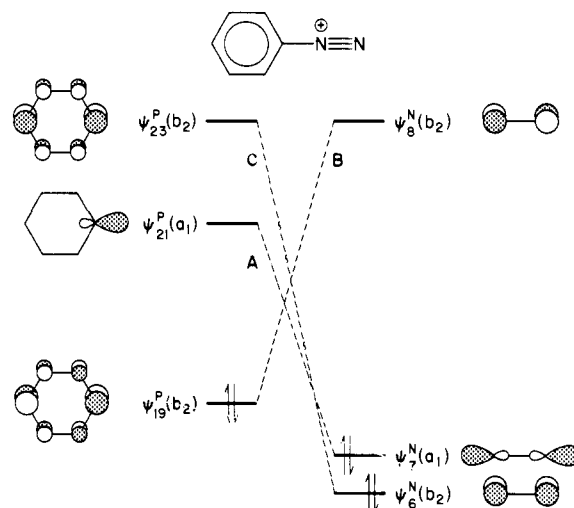

Figure 8. Important orbital interactions in the open structure (**5**) of the benzenediazonium ion. Orbitals classified under C_{2v} symmetry. Orbitals ψ_{20}^P and ψ_{22}^P (each of a_2 symmetry) and ψ_3^N and ψ_4^N (each of b_1 symmetry) are not involved in the interaction scheme because of symmetry.

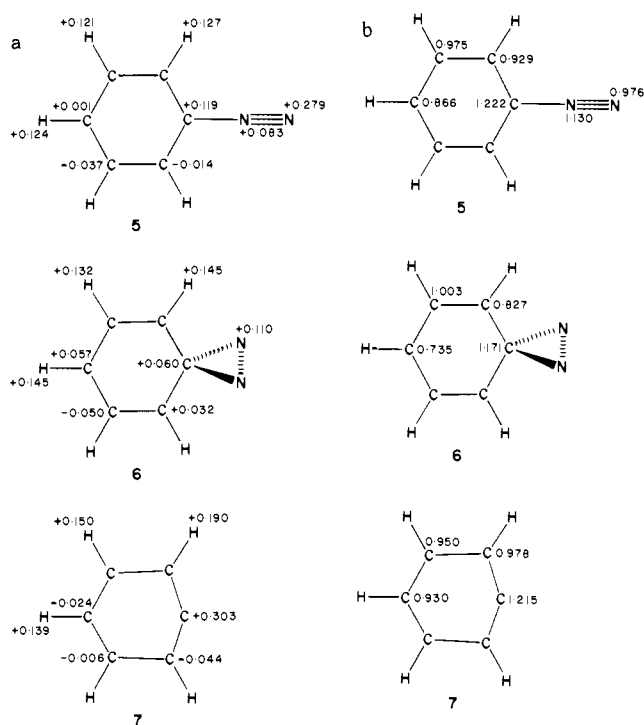

Figure 9. Total charges (a) and π -electron populations (b) in the benzenediazonium ion and related systems.

acceptor and π -electron acceptor than any of 35 substituents examined in a previous STO-3G study of substituted benzenes.³³ Thus, the net withdrawal of σ electrons from the ring is 0.532 for the N_2^+ substituent compared with values of 0.215 for F and 0.227 for NO_2 obtained previously.³³ Again, the net withdrawal of π electrons by N_2^+ is 0.106 compared with 0.037 for NO and 0.031 for NO_2 .

In the bridged structure (**6**) of the benzenediazonium ion, the C-N lengths are considerably shorter than in the corresponding structure (**2**) for the methanediazonium ion, indicating a much tighter complex. Indeed, this species **6** may well be considered as a spirodiazirine cation. The main orbital interactions are of interest and are reproduced in Figure 10. The primary interaction involves the appropriate filled π orbital (ψ_6^N) of N_2 with the empty σ -type orbital (ψ_{21}^P) of $C_6H_5^+$. This three-center bonding leads to a familiar^{16,34} lengthening of the

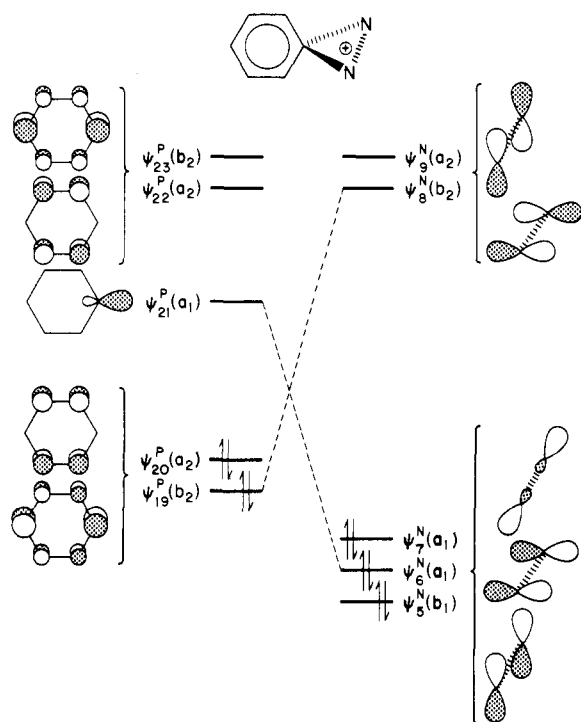

Figure 10. Important orbital interactions in the symmetric bridged structure (6) of the benzenediazonium ion. Orbitals classified under C_{2v} symmetry.

$N\equiv N$ link. An additional important interaction involves electron donation from the filled ψ_{19}^P orbital into the π^* orbital (ψ_8^N) of N_2 . This would account for the strong alternation of ring bond lengths in **6**. The change in hybridization at C_1 , i.e., the increasing p character, is likely to be responsible for part of the increase in the length of C_1-C_2 . The interaction between ψ_7^N and ψ_{21}^P is likely to be greatly reduced compared with the corresponding interaction in the open structure (**5**) because of the poor overlap between the parts of these two orbitals in which the electron density is concentrated. The interaction between ψ_{20}^P and ψ_9^N is also likely to be small because of poor overlap.

The calculated binding energy of the open benzenediazonium ion (**5**) with respect to phenyl cation + N_2 is 44.3 kcal mol⁻¹ (Table II), somewhat less than the STO-3G binding energy (51.6 kcal mol⁻¹) for the methanediazonium ion (**1**). This result is somewhat perplexing, since on the surface at least it would appear that **5** with a calculated C-N bond length of 1.469 Å is more strongly bound than **1** where the corresponding C-N length is 1.557 Å. We would suggest that the binding energies reflect the lower stability (in the gas phase) of CH_3^+ compared with $C_6H_5^+$ rather than a higher intrinsic stability for **1** compared with **5**. The small methyl cation has difficulty in accommodating a full positive charge and benefits greatly on binding with nitrogen from the possibility of dispersing the charge more widely. The calculated binding energy reflects, in part, this effect, together with that of conventional bonding. In the phenyl cation, the conventional bonding is stronger but there is less energy gain from the charge dispersal effect. The net result is lower binding energy in **5** than in **1**.

For the bridged structure **6**, the calculated binding energy is 10.0 kcal mol⁻¹, in this case slightly greater than the value (4.9 kcal mol⁻¹) for the corresponding $CH_3N_2^+$ structure **2**. The long bridging C-N bonds in **2** hinder any stabilization due to charge dispersion. In contrast, **6** is a much tighter structure and it is not surprising that there is a significant binding energy.

The N_α, N_β Rearrangement in the Benzenediazonium Ion.

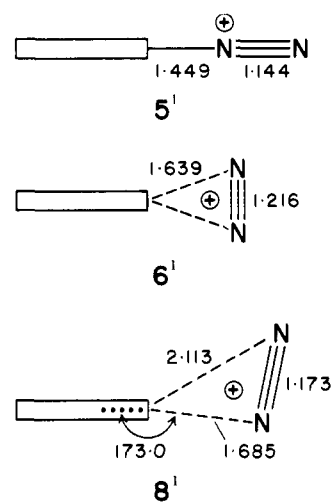

Figure 11. Model optimized transition state (**8'**) for N_α, N_β rearrangement in the benzenediazonium ion and model optimized related systems. See text for details of model used.

Table IV. Calculated Total Energies (hartrees) for Model Optimized Structures of the Benzenediazonium Ion and Related Systems

		STO-3G/STO-3G
$C_6H_5N_2^+$ (open)	5'	-334.556 23
$C_6H_5N_2^+$ (symmetric bridged)	6'	-334.500 09
$C_6H_5N_2^+$ (transition state)	8'	-334.483 13
$C_6H_5^+$	7'	-226.944 15

The N_α, N_β rearrangement in the benzenediazonium ion has aroused considerable experimental interest and therefore warrants theoretical study. The key question is whether the transition state for this rearrangement has the symmetrically bridged structure **6** or some alternative structure. We attempt to answer this question here.

Initial calculations were carried out on structures connecting **5** and **6** obtained by simple interpolation of the structural parameters. These preliminary calculations suggested strongly that the transition state in the N_α, N_β rearrangement is not **6** but rather some unsymmetrically bridged structure. The symmetrically bridged structure **6** is likely to be an intermediate in this process.

Unfortunately, the size of the benzenediazonium system makes a complete resolution of the transition state a costly process. For this reason, we have adopted in our direct transition state calculations a simplified model in which the benzene ring is taken to have C-C lengths of 1.40 Å and C-H lengths of 1.083 Å. The N_2 fragment is allowed complete freedom within an overall C_s constraint. Because of the assumed ring geometry, we emphasize the qualitative rather than the quantitative results within this model. The calculated transition state structure (**8'**) is shown in Figure 11 together with structures for the related systems obtained using the same model. Corresponding energies are shown in Table IV and a schematic energy profile in Figure 12.

The optimized parameters in the model structures **5'** and **6'** (Figure 11) are close to corresponding values in the fully optimized structures **5** and **6** (Figure 7). In addition, the energy difference between the open (**5'**) and symmetrically bridged (**6'**) structures within this model is 35.2 kcal mol⁻¹, which is very close to the value (34.3 kcal mol⁻¹) obtained for the fully optimized structures, despite the limitations of the ring geometry in the model. This lends some confidence to our model predictions for the transition state.

The structure of **8'** resembles that of the open (**5'**) somewhat

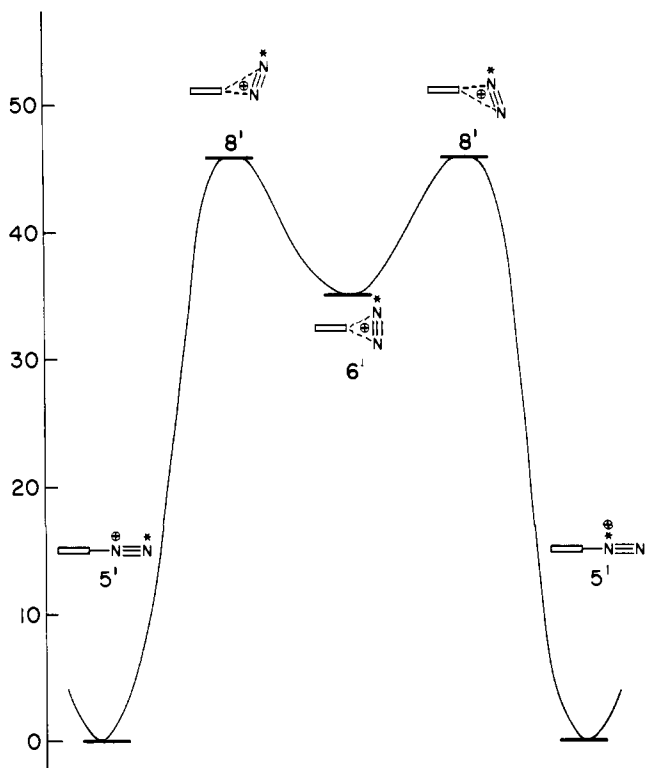

Figure 12. Schematic energy profile (STO-3G) for N_{α}, N_{β} rearrangement in the benzenediazonium ion.

more than the bridged ($6'$) benzenediazonium ion in contrast to the expectations of the Hammond postulate.³⁵ Indeed the calculated charge distributions in $5'$ and $8'$ are very similar. One of the two C-N bonds in $8'$ is quite weak (1.685 Å) and the other (2.113 Å) virtually nonexistent. The N≡N length in $8'$ lies between the values calculated for $5'$ and $6'$. We find that $8'$ lies about 11 kcal mol⁻¹ above $6'$ and about 46 kcal mol⁻¹ above $5'$. Since the STO-3G binding energy for 5 is 44 kcal (Table II), it seems likely that $8'$ is very weakly bound indeed.

In the light of our results for the methanediazonium ion (Table II), it appears likely that our STO-3G binding energy for 5 is too large by about 10–15 kcal mol⁻¹, thus reducing its value to 30–35 kcal mol⁻¹. In addition, experience with related systems suggests that the STO-3G energy difference (46 kcal mol⁻¹) between $5'$ and $8'$ is overestimated, possibly by as much as 10–15 kcal mol⁻¹. Our calculations therefore indicate that nitrogen scrambling in the benzenediazonium ion can take place (1) via a direct 1,2-intramolecular shift or (2) via a dissociation-recombination mechanism



with both processes requiring about 30–35 kcal mol⁻¹.

There is experimental evidence^{36–38} that both of these processes can take place in solution. Indeed, our transition state structure $8'$ appears to be remarkably consistent with the experimental data. The current view^{36c,37,38} is that the transition state for the N_{α}, N_{β} rearrangement has a very weak bond between the α nitrogen and carbon and no significant bonding to the β nitrogen. This description quite aptly fits our theoretical structure $8'$. The intermediacy of a symmetric bridged (or equivalently, a spirodiazirine) structure, although favored originally,^{36a,b} now seems to be open to question.^{36c,37,38} Our calculations suggest that such a structure (6) lies in a shallow, high-energy potential well (cf. Figure 12), so it is not surprising that evidence for its existence is difficult to obtain.

Conclusions

Several important and interesting points emerge from this study.

(1) The favored structure of the methanediazonium ion (MDI) is an open structure with a C-N length slightly longer than normal C-N bonds and an N≡N length very similar to that in molecular nitrogen.

(2) The favored structure of the benzenediazonium ion (BDI) is also an open structure but with a considerably shorter C-N bond reflecting considerable double bond character. The N≡N length is again similar to that in molecular nitrogen.

(3) Despite the longer C-N bond in MDI, the binding energy calculated with respect to the appropriate parent cation + N₂ is predicted to be greater for MDI than for BDI. This is attributed to a lower stability (in the gas phase) of CH₃⁺ compared with C₆H₅⁺ rather than to a higher intrinsic stability for MDI compared with BDI.

(4) The N_{α}, N_{β} rearrangement in open MDI is predicted to proceed via a symmetric bridged transition state.

(5) In contrast, the N_{α}, N_{β} rearrangement in BDI is predicted to proceed via an asymmetric transition state in which one of the nitrogens is weakly bound to a ring carbon and the other not at all. A symmetric bridged structure, which may alternatively be considered as a spirodiazirine cation, is predicted to be a metastable intermediate in this rearrangement, lying in a high-energy shallow potential well.

(6) The N₂⁺ substituent is predicted to be a powerful σ -electron acceptor, considerably more powerful, for example, than NO₂ and F. It is also a strong π -electron acceptor.³⁹

Acknowledgments. We are indebted to Dr. Dieter Poppinger for the use of his gradient optimization programs and to Dr. L. N. Mander and Mr. G. McLaughlin for helpful comments.

References and Notes

- P. Griess, *Justus Liebigs Ann. Chem.*, **120**, 125 (1861).
- Reviews: (a) J. T. Keating and P. S. Skellin in "Carbocation Ions", Vol. II, G. A. Olah and P. v. R. Schleyer, Ed., Wiley-Interscience, New York, N.Y., 1970; (b) H. G. Richey and J. M. Richey in ref 2a; (c) L. Friedman in ref 2a; (d) H. Zollinger, "Azo and Diazo Chemistry", Interscience, New York, N.Y., 1961; (e) P. A. S. Smith, "Open Chain Nitrogen Compounds", Vol. 1 and 2, W. A. Benjamin, New York, N.Y., 1965, 1966.
- H. Zollinger, *Acc. Chem. Res.*, **6**, 335 (1973).
- W. Kirmse, *Angew. Chem., Int. Ed. Engl.*, **15**, 251 (1976).
- M. S. Foster and J. L. Beauchamp, *J. Am. Chem. Soc.*, **94**, 2425 (1972).
- Reviews: (a) L. Radom and J. A. Pople, *MTP Int. Rev. Sci.: Phys. Chem., Ser. One*, **1**, 71 (1972); (b) W. J. Hehre, *Acc. Chem. Res.*, **9**, 399 (1976).
- Reviews: (a) J. A. Pople, *Int. J. Mass Spectrom. Ion Phys.*, **19**, 89 (1976); (b) W. J. Hehre, *Acc. Chem. Res.*, **8**, 369 (1975); (c) L. Radom, D. Poppinger, and R. C. Haddon in "Carbocation Ions", Vol. V, G. A. Olah and P. v. R. Schleyer, Ed., Wiley-Interscience, New York, N.Y., 1976; (d) W. J. Hehre, in "Modern Theoretical Chemistry", H. F. Schaefer, Ed., Plenum Press, New York, N.Y., 1977.
- (a) P. Schuster and O. E. Polansky, *Monatsh. Chem.*, **96**, 396 (1965); (b) M. Sukigara and S. Kikuchi, *Bull. Chem. Soc. Jpn.*, **40**, 461 (1967); (c) E. M. Evieth and R. J. Cox, *J. Phys. Chem.*, **71**, 4082 (1967); (d) L. A. Kazitsyna, N. B. Dzegilenko, A. V. Upadyshva, V. V. Mishchenko, and O. A. Reutov, *Izv. Akad. Nauk SSSR, Ser. Khim.*, 1848 (1967); (e) D. A. Bocharov, N. P. Gambaryan, V. V. Mishchenko, and L. A. Kazitsyna, *Dokl. Akad. Nauk SSSR*, **175**, 681 (1967); (f) L. Klasinc and D. Schulte-Frohlinde, *Z. Phys. Chem. (Frankfurt am Main)*, **60**, 1 (1968); (g) V. M. Treiger, I. L. Bagal, and B. A. Porai-Koshits, *J. Org. Chem. USSR (Engl. Transl.)*, **6**, 2549 (1970); (h) Z. Yoshida and T. Kobayashi, *Bull. Chem. Soc. Jpn.*, **45**, 742 (1972); (i) H. Kashiwagi, S. Iwata, T. Yamaoka, and S. Nagakura, *ibid.*, **46**, 417 (1973); (j) V. M. Treiger and I. L. Bagal, *J. Org. Chem. USSR (Engl. Transl.)*, **10**, 2512 (1974); (k) V. Y. Bespalov and M. A. Kuznetsov, *J. Struct. Chem.*, **15**, 648 (1974).
- G. W. Van Dine and R. Hoffmann, *J. Am. Chem. Soc.*, **90**, 3227 (1968).
- H. M. Niemeyer, *Helv. Chim. Acta*, **59**, 1133 (1976).
- J. D. Dill, P. v. R. Schleyer, and J. A. Pople, *J. Am. Chem. Soc.*, **99**, 1 (1977); J. D. Dill, H. U. Wagner, P. v. R. Schleyer, and J. A. Pople, unpublished.
- W. J. Hehre, W. A. Lathan, R. Ditchfield, M. D. Newton, and J. A. Pople, Program No. 236, QCPE, University of Indiana, Bloomington, Ind.
- D. Poppinger, *Chem. Phys. Lett.*, **34**, 332 (1975).
- W. J. Hehre, R. F. Stewart, and J. A. Pople, *J. Chem. Phys.*, **51**, 2657 (1969).
- R. Ditchfield, W. J. Hehre, and J. A. Pople, *J. Chem. Phys.*, **54**, 724 (1971).
- W. A. Lathan, W. J. Hehre, and J. A. Pople, *J. Am. Chem. Soc.*, **93**, 808

- (1971).
- (17) W. A. Lathan, L. A. Curtiss, W. J. Hehre, J. B. Lisle, and J. A. Pople, *Prog. Phys. Org. Chem.*, **11**, 175 (1974).
- (18) D. Poppinger, *Chem. Phys. Lett.*, **35**, 550 (1975).
- (19) R. S. Mulliken, *J. Chem. Phys.*, **23**, 1833 (1955).
- (20) L. Radom and H. F. Schaefer, *J. Am. Chem. Soc.*, **99**, 7522 (1977).
- (21) J. D. Dill, P. v. R. Schleyer, J. S. Binkley, R. Seeger, J. A. Pople, and E. Hasebach, *J. Am. Chem. Soc.*, **98**, 5428 (1976).
- (22) At the STO-3G level, this is in fact the highest occupied molecular orbital, but at the 4-31G and more sophisticated²³ levels of theory, the highest occupied MOs on N₂ are the π -type orbitals. The energy differences between these levels are, however, quite small.
- (23) P. E. Cade, K. D. Sales, and A. C. Wahl, *J. Chem. Phys.*, **44**, 1973 (1966).
- (24) D. R. Lide, *J. Chem. Phys.*, **27**, 343 (1957).
- (25) F. P. Lossing and G. P. Semeluk, *Can. J. Chem.*, **48**, 955 (1970).
- (26) (a) P. C. Hariharan, W. A. Lathan, and J. A. Pople, *Chem. Phys. Lett.*, **14**, 385 (1972); (b) P. C. Hariharan and J. A. Pople, *ibid.*, **16**, 217 (1972); (c) W. A. Lathan, L. Radom, W. J. Hehre, P. C. Hariharan, and J. A. Pople, *Fortschr. Chem. Forsch.*, **40**, 1 (1973); (d) B. Zurawski, R. Ahlrichs, and W. Kutzelnigg, *Chem. Phys. Lett.*, **21**, 309 (1973); (e) J. Weber and A. D. McLean, *J. Am. Chem. Soc.*, **98**, 875 (1976); J. Weber, M. Yoshimine and A. D. McLean, *J. Chem. Phys.*, **64**, 4159 (1976).
- (27) D. H. Liskow, C. F. Bender, and H. F. Schaefer, *J. Chem. Phys.*, **57**, 4509 (1972).
- (28) F. W. Schneider and B. S. Rabinovitch, *J. Am. Chem. Soc.*, **84**, 4215 (1962).
- (29) Because of the artificial constraint that the bridging carbon in **2a** should lie on the perpendicular bisector of the N-N bond, **2a** is not a true stationary point. However, **2a** and **2b** are effectively freely interconverting structures and so the arguments pertaining to transition states and intermediates apply to them both.
- (30) (a) O. Andresen and C. Romming, *Acta Chem. Scand.*, **16**, 1882 (1962); (b) C. Romming and K. Waerstad, *Chem. Commun.*, 299 (1965).
- (31) C. Romming, *Acta Chem. Scand.*, **17**, 1444 (1963).
- (32) The experimental bond length in N₂ is 1.094 Å: G. Herzberg, "Spectra of Diatomic Molecules", Van Nostrand, Princeton, N.J., 1950.
- (33) W. J. Hehre, L. Radom, and J. A. Pople, *J. Am. Chem. Soc.*, **94**, 1496 (1972).
- (34) See, for example, (a) L. Radom, J. A. Pople, V. Buss, and P. v. R. Schleyer, *J. Am. Chem. Soc.*, **94**, 311 (1972); (b) L. Radom, P. C. Hariharan, J. A. Pople, and P. v. R. Schleyer, *ibid.*, **95**, 6531 (1973); (c) W. J. Hehre, *ibid.*, **94**, 5919 (1972).
- (35) G. S. Hammond, *J. Am. Chem. Soc.*, **77**, 334 (1955).
- (36) (a) J. M. Insole and E. S. Lewis, *J. Am. Chem. Soc.*, **85**, 122 (1963); (b) E. S. Lewis and J. M. Insole, *ibid.*, **86**, 34 (1964); (c) E. S. Lewis and R. E. Holliday, *ibid.*, **91**, 426 (1969).
- (37) (a) C. G. Swain, J. E. Sheats, and K. G. Harbison, *J. Am. Chem. Soc.*, **97**, 783 (1975); (b) C. G. Swain, J. E. Sheats, D. G. Gorenstein, and K. G. Harbison, *ibid.*, **97**, 791 (1975); (c) C. G. Swain and R. J. Rogers, *ibid.*, **97**, 799 (1975); (d) C. G. Swain, J. E. Sheats, and K. G. Harbison, *ibid.*, **97**, 796 (1975).
- (38) R. G. Bergstrom, R. G. M. Landells, G. H. Wahl, and H. Zollinger, *J. Am. Chem. Soc.*, **98**, 3301 (1976).
- (39) NOTE ADDED IN PROOF. We have recently learned (P. v. R. Schleyer, personal communication) that independent calculations by H. U. Wagner and P. v. R. Schleyer have been carried out for some of the systems examined in this paper, yielding similar conclusions to those reached here.

Charge Distributions and Chemical Effects. 13. Ab Initio Study of the Charge Density-¹³C Nuclear Magnetic Resonance Shift Correlation for Ethylenic Carbon Atoms

Hervé Henry and Sándor Fliszár*

Contribution from the Department of Chemistry, University of Montreal,
Montreal, Quebec, H3C 3V1, Canada. Received February 13, 1976

Abstract: Ab initio charge distributions in ethylene and methyl derivatives thereof are examined (1) by means of Mulliken's scheme and (2) in terms of an approximation which does not involve halving of the overlap population terms among dissimilar overlap partners. The ¹³C NMR shifts of the vinylic C atoms are linearly related to the net atomic charges obtained from the latter approximation, whereby any increase in local electron density results in an upfield shift.

Numerous and often frustrating attempts at correlating ¹³C NMR shifts, δ_c , with carbon atomic charges were presented on the premises that one of the major factors governing the shielding of a specific nucleus is its local electron density.¹ The most accurate relationship, that found for alkanes,² indicates that δ_c increases (downfield shift) with decreasing positive character of the carbon atoms of this class of compounds. This result, which is at variance with common views, best illustrates the pitfalls in the growing praxis of indiscriminately interpreting ¹³C shifts in all systems as being strictly linearly related to electron density.

Recent theoretical progress³ in the calculation of ¹³C shifts gives some insight into the various contributions that can be related to detailed features of electronic structure. While these more rigorous approaches will hopefully result in some understanding of charge density-NMR shift correlations and their limitations, it is also felt that some detailed knowledge about the trends in series of closely related compounds is desirable, despite the fact that the significance or generality of any such empirical correlation is not known.

Here we present a relationship between ¹³C NMR shifts and net charges of sp² carbon atoms in alkyl-substituted ethylenes. At this point, we wish to emphasize that the fact that this re-

lationship turns out to be simple should not be used to lend unintended support for the still unwarranted view that chemical shifts are necessarily always linearly related to atomic charges. Indeed, chemical shift is a property of the interaction of the charge density with an external magnetic field and depends, therefore, not only on the value of the integrated charge density in the neighborhood of a nucleus but also on the magnetic susceptibility of that charge density. Finally, this study illustrates the care which is required in the calculation of atomic charges if one wishes to use them in the evaluation of property-charge relationships.

Calculation of Charges

Population analyses were obtained from ab initio (STO-3G) calculations involving optimization of all (geometry and scale factor) variational parameters, along the lines described earlier;⁴ they were calculated following Mulliken's scheme,⁵ implying the half-and-half partitioning of all overlap population terms (eq 1, in standard notation),

$$N(k) = 2 \sum_i \sum_r \left(c_{ir}^2 + \sum_{l \neq k} c_{ir} c_{isl} S_{rksl} \right) \quad (1)$$

thus providing sets of net charges, $\{q^0\}$, in a well-defined frame